

timed such that shock arrival at the polished surface occurs during the period of peak light intensity. The xenon flash lamp is double-pulsed, a technique described by Emmett and Schawlow⁶ and by Goncz and Park.⁷

A. Optical Lever Technique

Figure 2 illustrates the optical lever technique. The polished target is placed at the end of a hypervelocity range and the light source grid is placed a fixed distance, d , from the target. An objective lens is used to focus the grid onto the slit plane. A second lens, internal to the camera, focuses the slit onto the film. Lines of light passed by the grid are cut into dots of light by the slit. These dots of light are streaked across the film.

As the projectile strikes the target, the shock wave radiates to the polished surface and is reflected. Because the shock strikes the polished surface at an angle, the surface is turned. This turning angle depends upon the shock strength as well as the emergence angle, and results in an optical lever deflection on the film. Multi-stepped shock waves produce successive deflections as each step arrives at the polished surface. From the film record, shock velocity and particle velocity can be measured for each step. These values are used with the Rankine-Hugoniot jump conditions^{2,5} to compute shock strength, density, and energy.

Shock velocity is calculated as

$$U = U_{app} \sin c. \quad (1)$$

The apparent velocity U_{app} is measured as the local cotangent of b (in Fig. 2). The emergence angle c is measured by knowing the individual line position on the polished surface relative to impact and by assuming a direct ray path between impact and arrival at the line position.

Particle velocity is calculated as

$$u = [U_{app} \sin(a/4d)] / \{\cos[c - (a/4d)]\}, \quad (2)$$

where a is the deflection corrected for film demagnification. The usual free-surface approximation is used in computing the particle velocity for the main shock and ramp and is included in the above relation. The

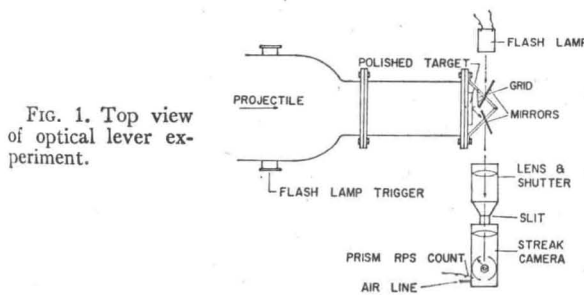

FIG. 1. Top view of optical lever experiment.

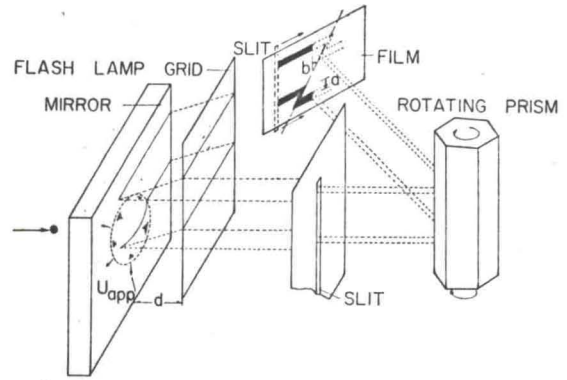

FIG. 2. Optical lever technique.

relation for particle velocity was described by Ahrens and Gregson and is a general relation for any shock emergence angle; whereas a relation by Fowles is restricted to shallow emergence angles.

The free-surface approximation is generally used to compute the amplitude of the elastic shock. This assumes a fluid behavior of the material. The term "pressure" is usually redefined as a "stress" which is normal to the wavefront. Errors in using this assumption for the elastic wave may be as much as 10% of the true stress amplitude. The free-surface approximation has not been used to compute particle velocity and stress of the elastic shock for this experiment. Instead an analysis is used which considers an incident elastic shock reflecting at a free boundary as another dilatational shock and a shear stress shock.

The energy of the incident compressional shock is proportioned between the two reflected shocks as a function of the incidence angle. From energy considerations of any shock, the total energy is partitioned equally between internal and kinetic energy. For most elastic shocks, the stresses are such that the slight temperature increase behind the shock front results in little of the available internal energy lost to propagate the shock. Assuming no energy is lost, the kinetic energy of an incident elastic shock can be proportioned between the kinetic energy of the two reflected shocks. The kinetic energy of a unit volume for the incident shock is

$$E = 1/2 \rho_0 u_1^2, \quad (3)$$

where E is the kinetic energy, u_1 is the particle velocity, and ρ_0 is the material density before the shock arrival. The kinetic energy of a unit volume of the reflected shocks is

$$E = 1/2 \rho_0 (u_2 + u_3)^2, \quad (4)$$

where u_2 and u_3 are particle velocities of the dilatational and shear-stress shocks respectively. If it is assumed that errors in an infinitesimal-amplitude-elastic-wave analysis are small compared to a finite-amplitude-wave analysis, the reflected shock particle velocities can be described in terms of the incident particle

⁶ J. L. Emmett and A. L. Schawlow, Appl. Phys. Letters 2, 204 (1963).

⁷ J. H. Goncz and S. W. Park, Microwaves, p. 34 (1965).